

Scan QR code to visit the product page:



If you have any questions regarding our products, please visit us at www.displays2go.com or contact D2G customer service 844-221-3388.

INSTALLATION MANUAL

VWALL3X3WR



200x200/300x300
400x200/400x400
600x400



50kgx9/110lbsx9

 **Read the entire instruction manual before you start installation and assembly. If you have any questions regarding any of the instructions or warnings, please contact your local distributor for assistance.**

CAUTION

- Use with products heavier than the rated weights indicated may result in instability causing possible injury.
- Please closely follow the assembly instructions. Improper installation may result in damage or serious personal injury.
- Safety gear and proper tools must be used. This product should only be installed by professionals.
- Make sure that the supporting surface will safely support the combined weight of the equipment and all attached hardware and components.
- Use the mounting screws provided and **DO NOT OVER TIGHTEN** mounting screws.
- This product contains small items that could be a choking hazard if swallowed. Keep these items away from children.
- This product is intended for indoor use only. Using this product outdoors could lead to product failure and personal injury.

Required for Installation

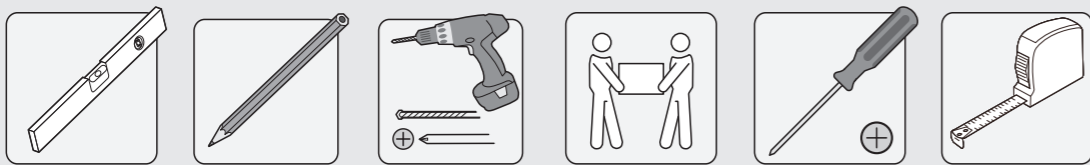

Component Checklist

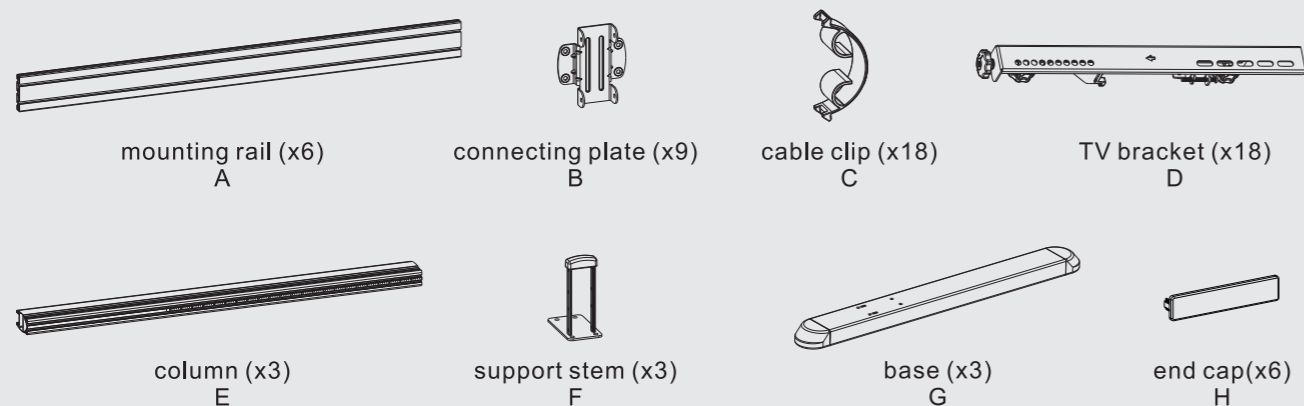

Component Checklist

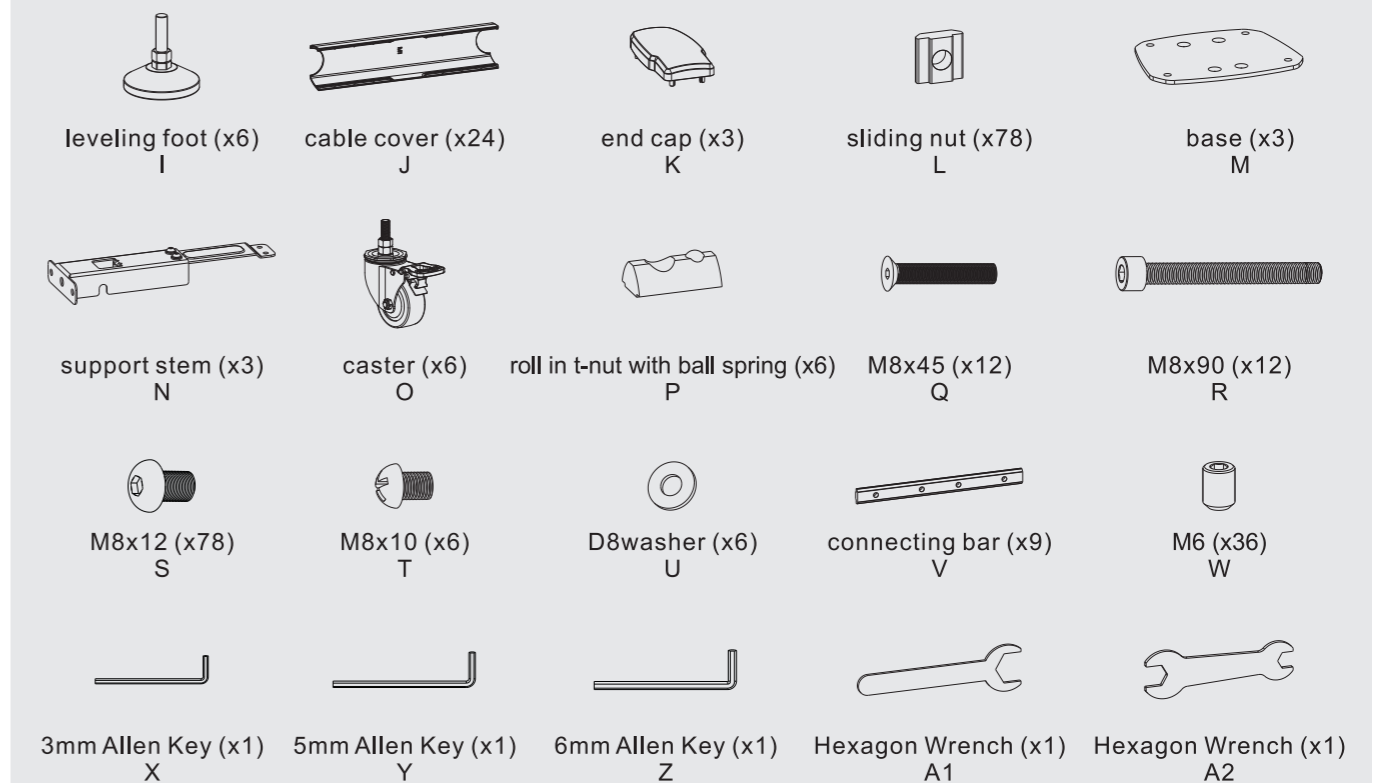

IMPORTANT: Ensure that you have received all parts according to the component checklist prior to installation. If any parts are missing or faulty, contact your place of purchase for a replacement.

Package Mx9

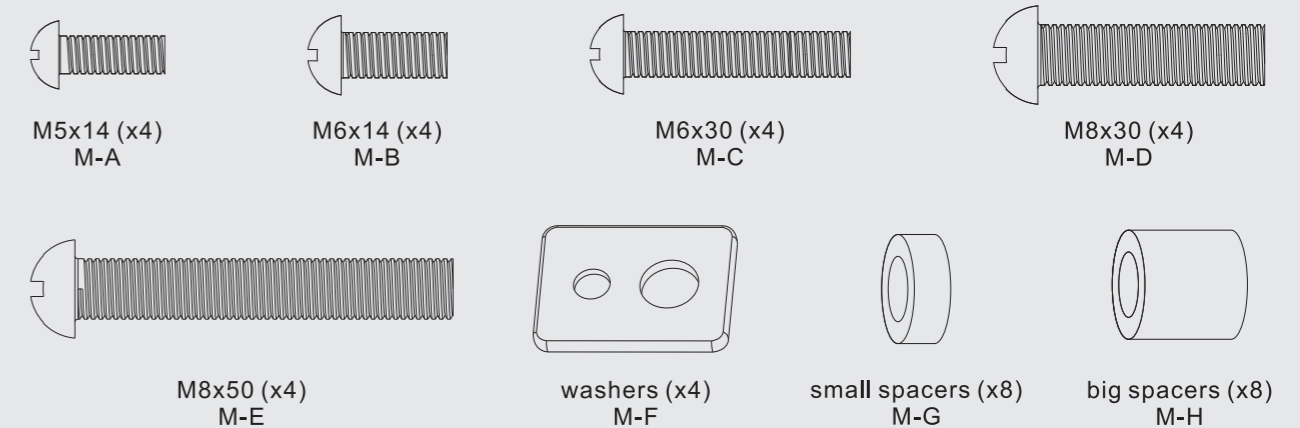

Package Wx3

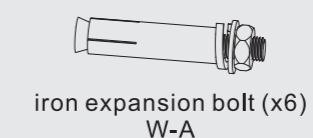

1. Attach Connecting Plate to the Column

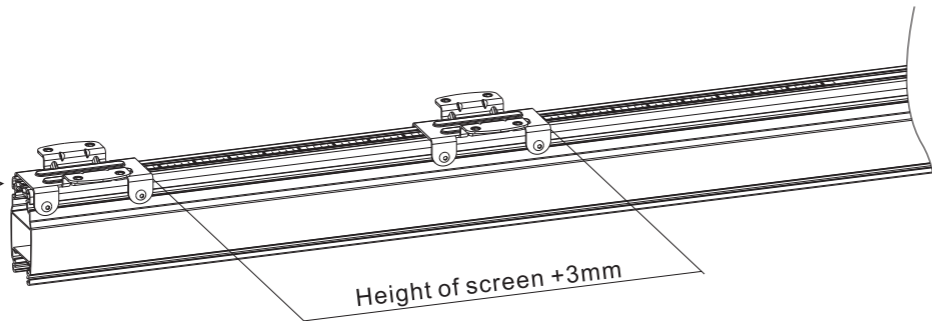
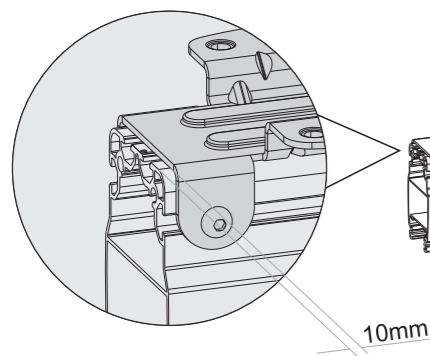
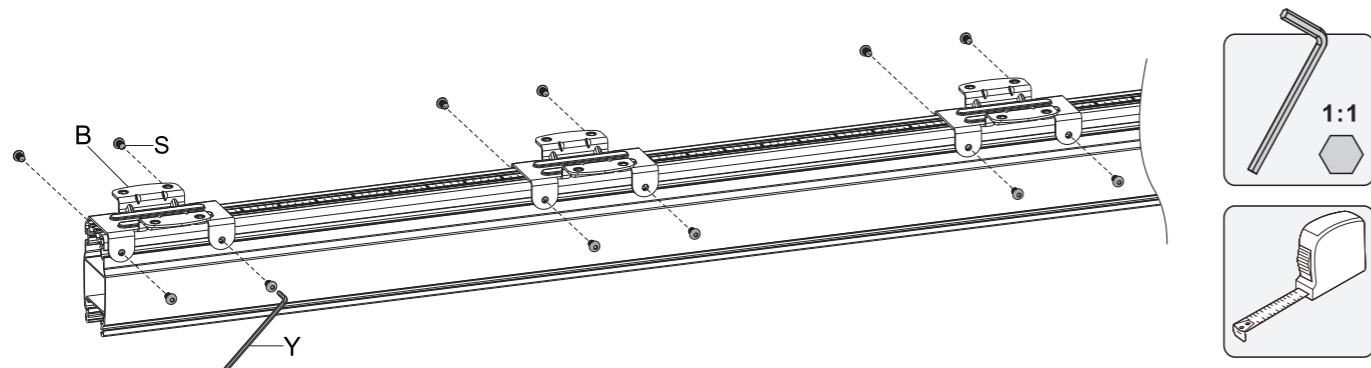
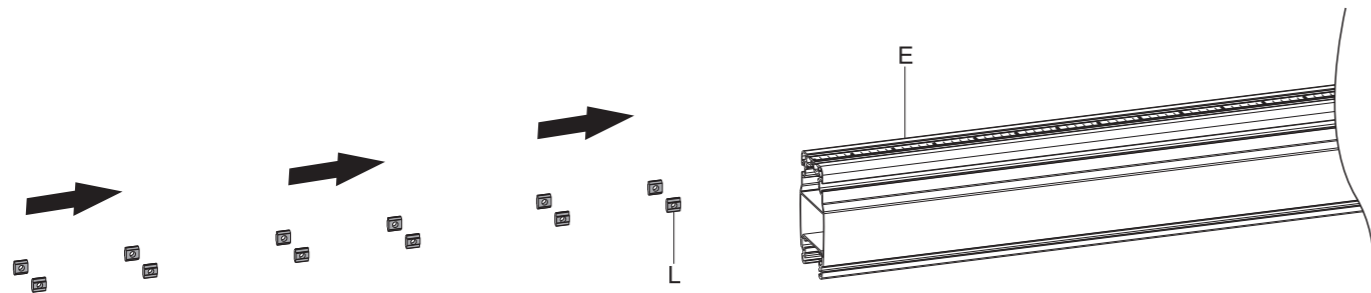

Note: The space apart the connect plates is the height of the screen plus and extra 3 mm.

2. Extend the Mounting Rail

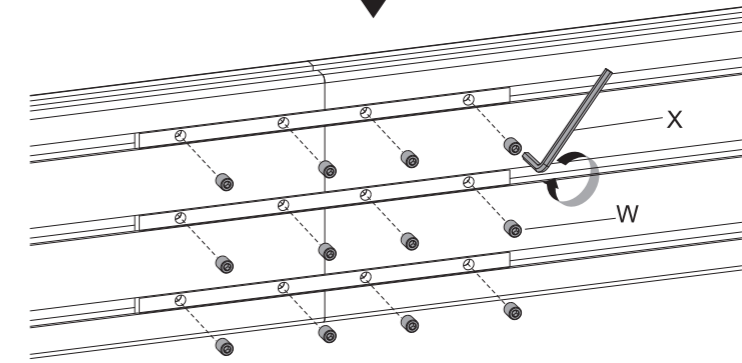
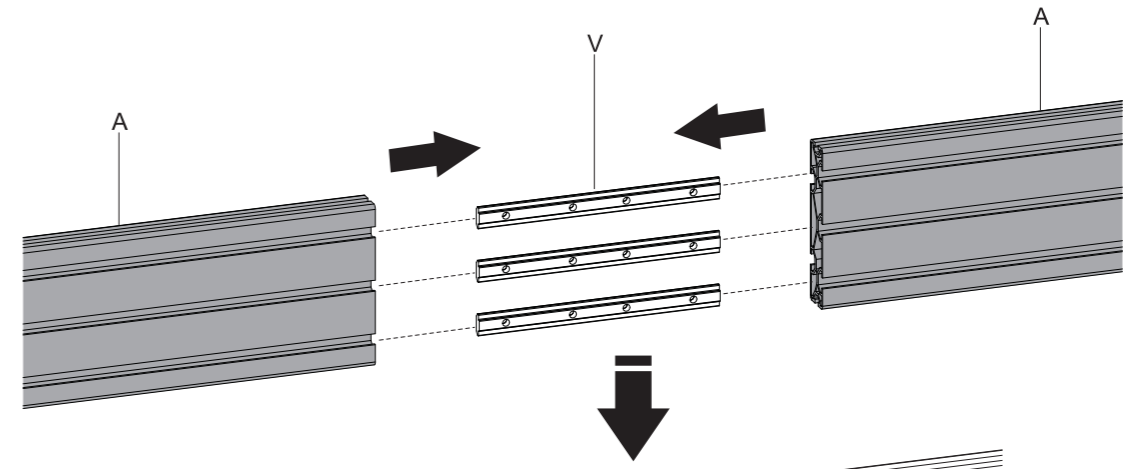

3. Attach Column to the Mounting Rail

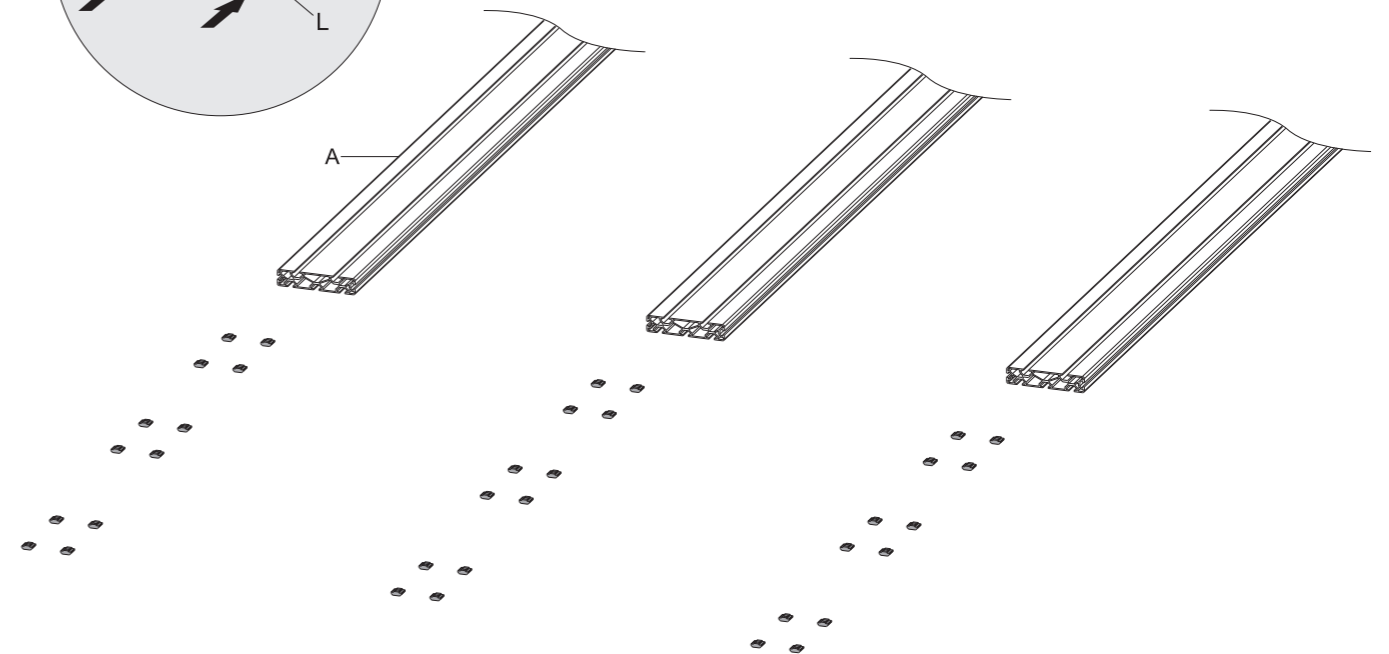
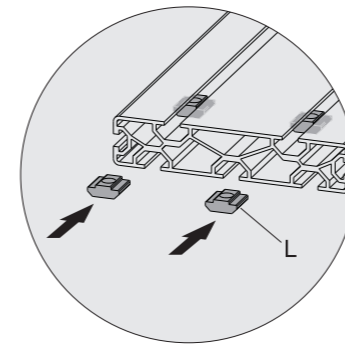

Note: Ensure the gap between the nuts halves on both sides are equal.

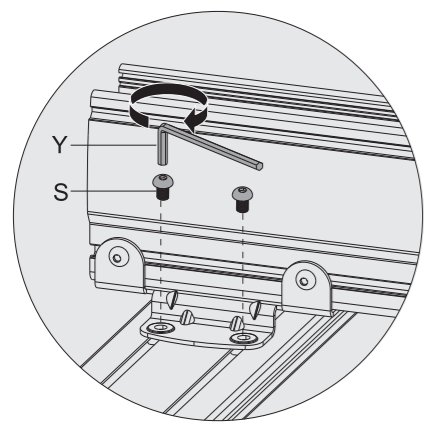
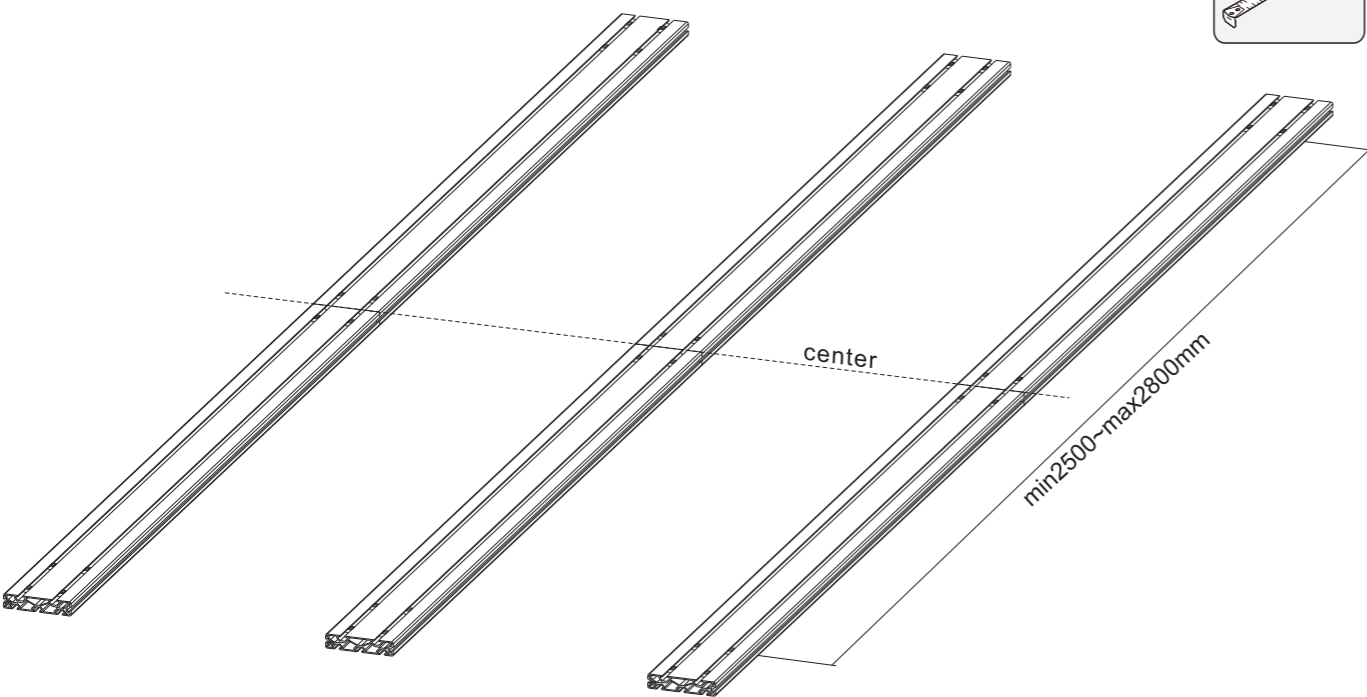

Note: Make sure the position of mounting rails are parallel before any AV equipment is fitted.

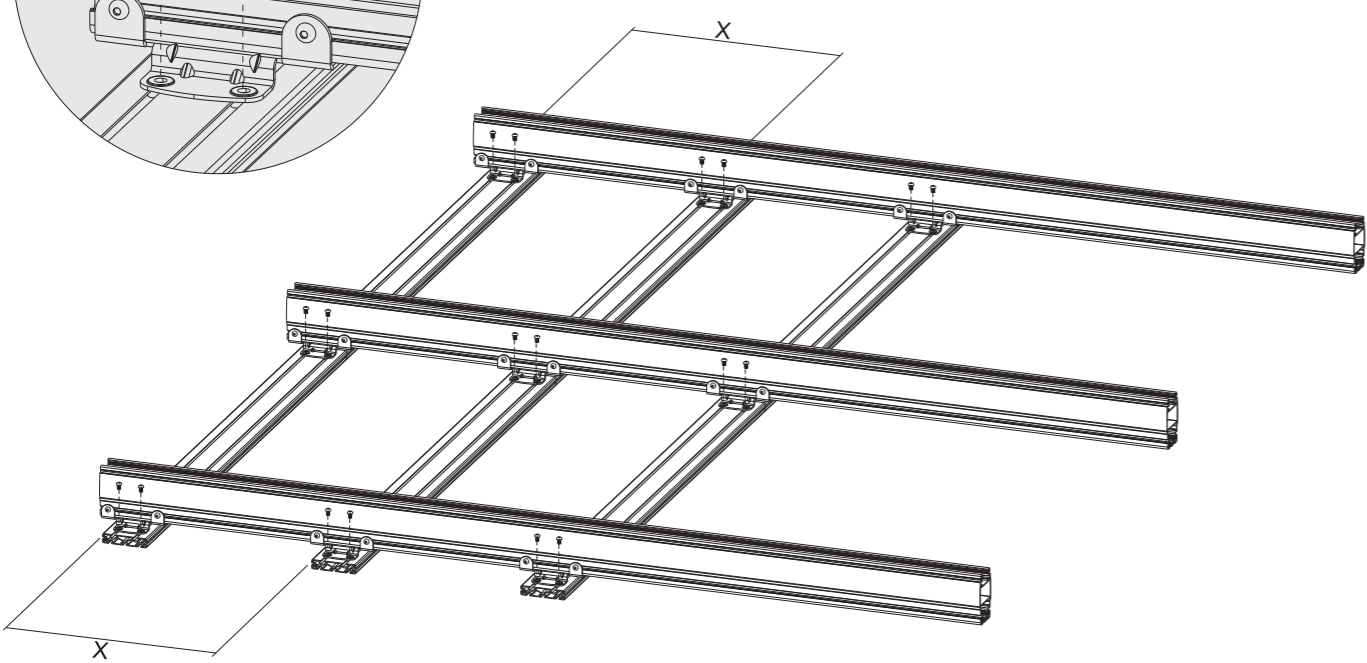

4. Install the End Cap

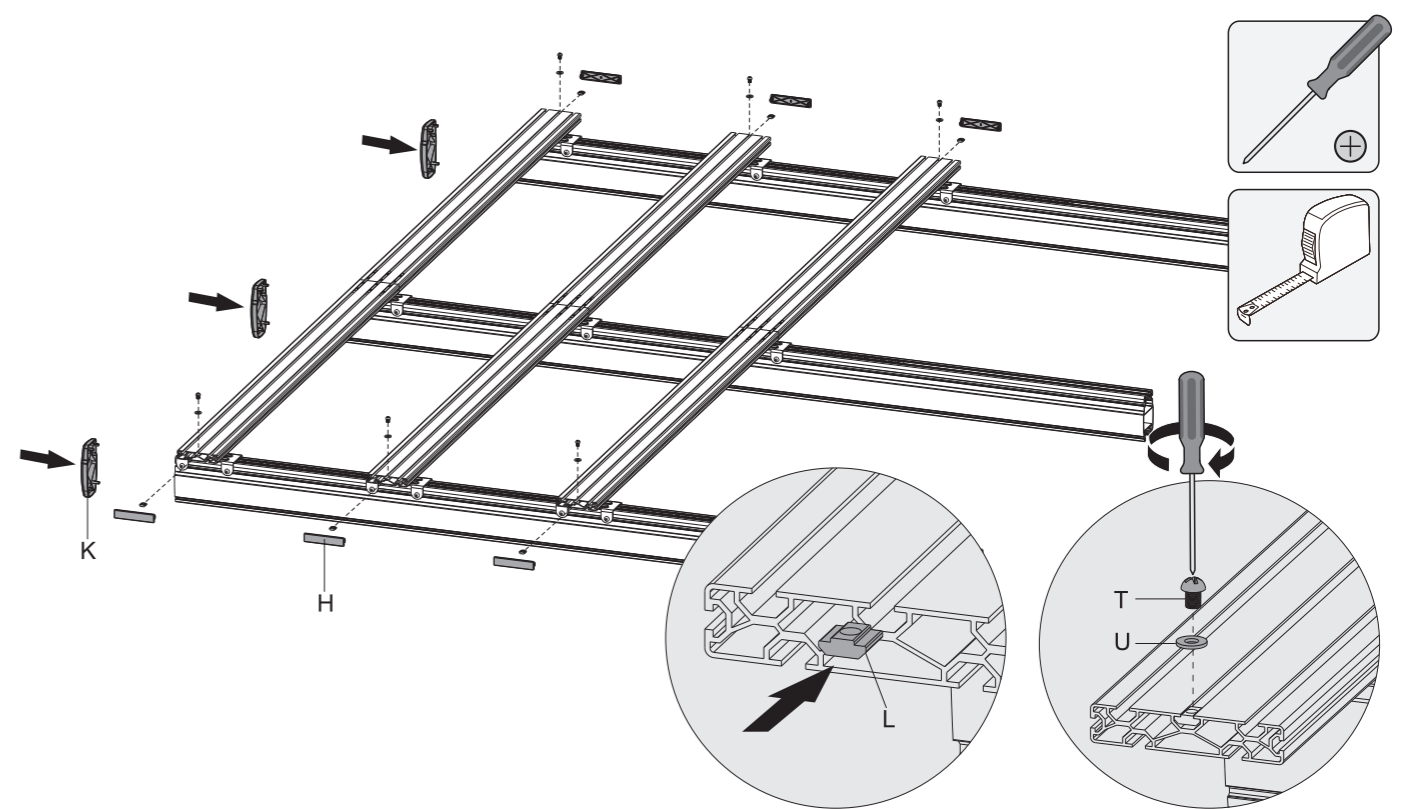

5a-1. Assemble the Base

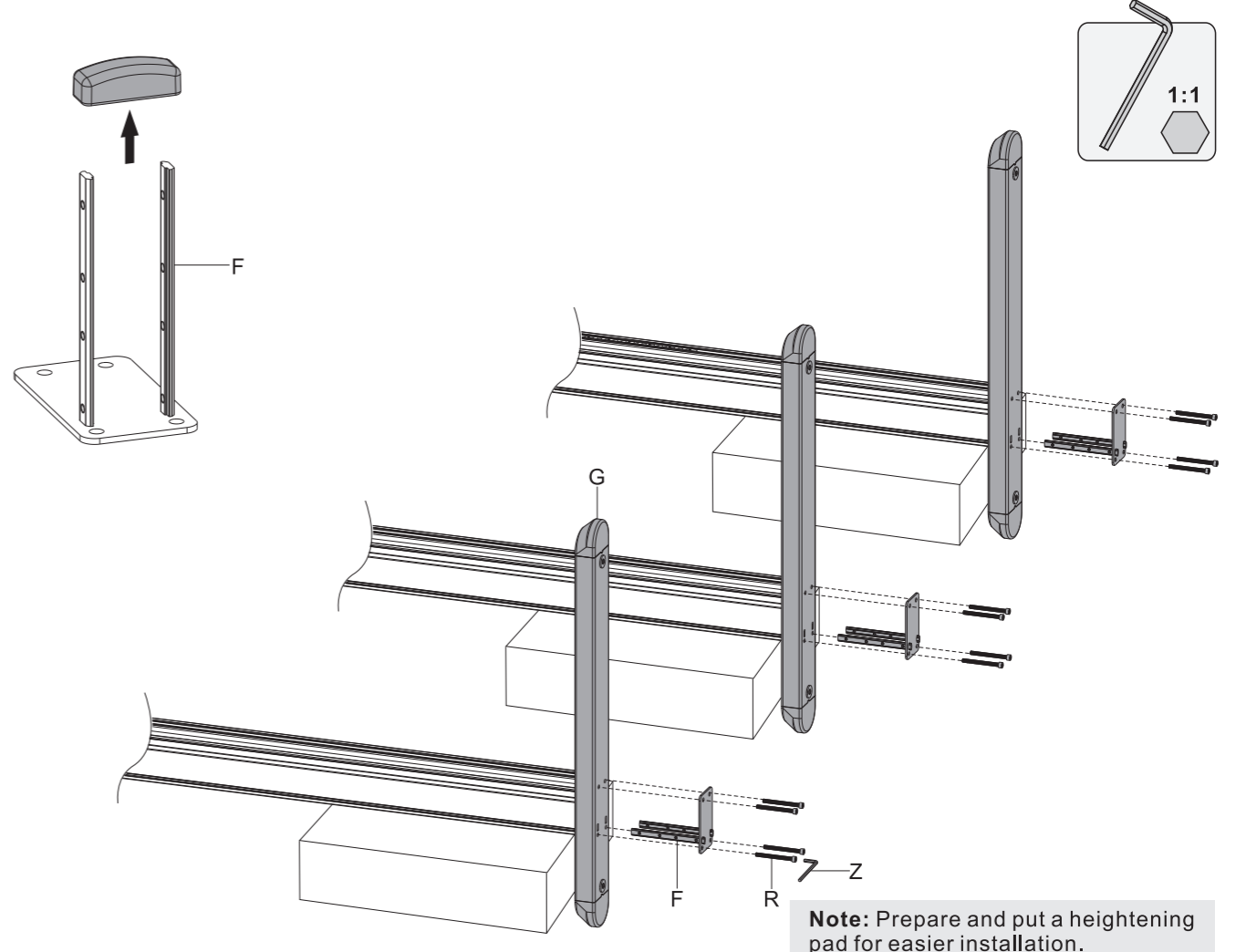

Note: Prepare and put a heightening pad for easier installation.

5a-2a. Assemble the Base

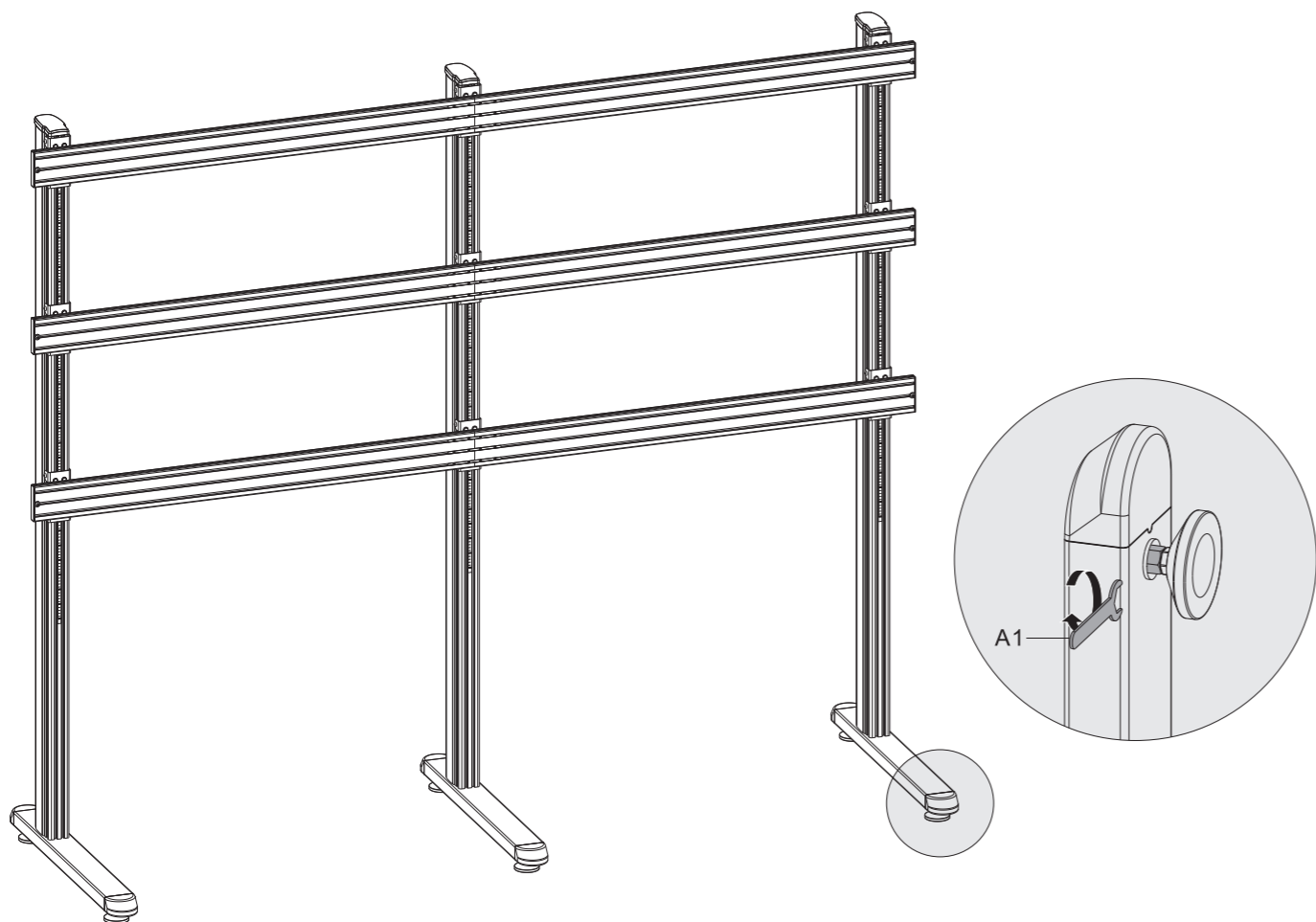
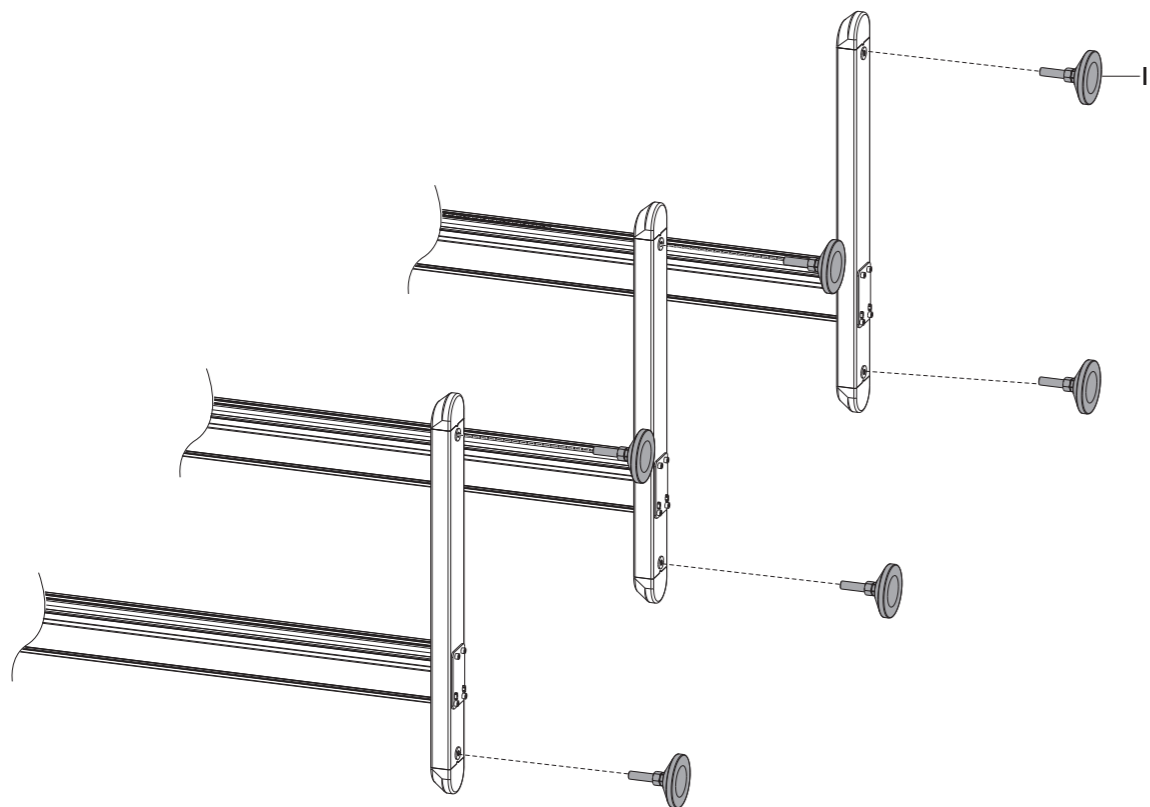

5a-2b. Assemble the Base

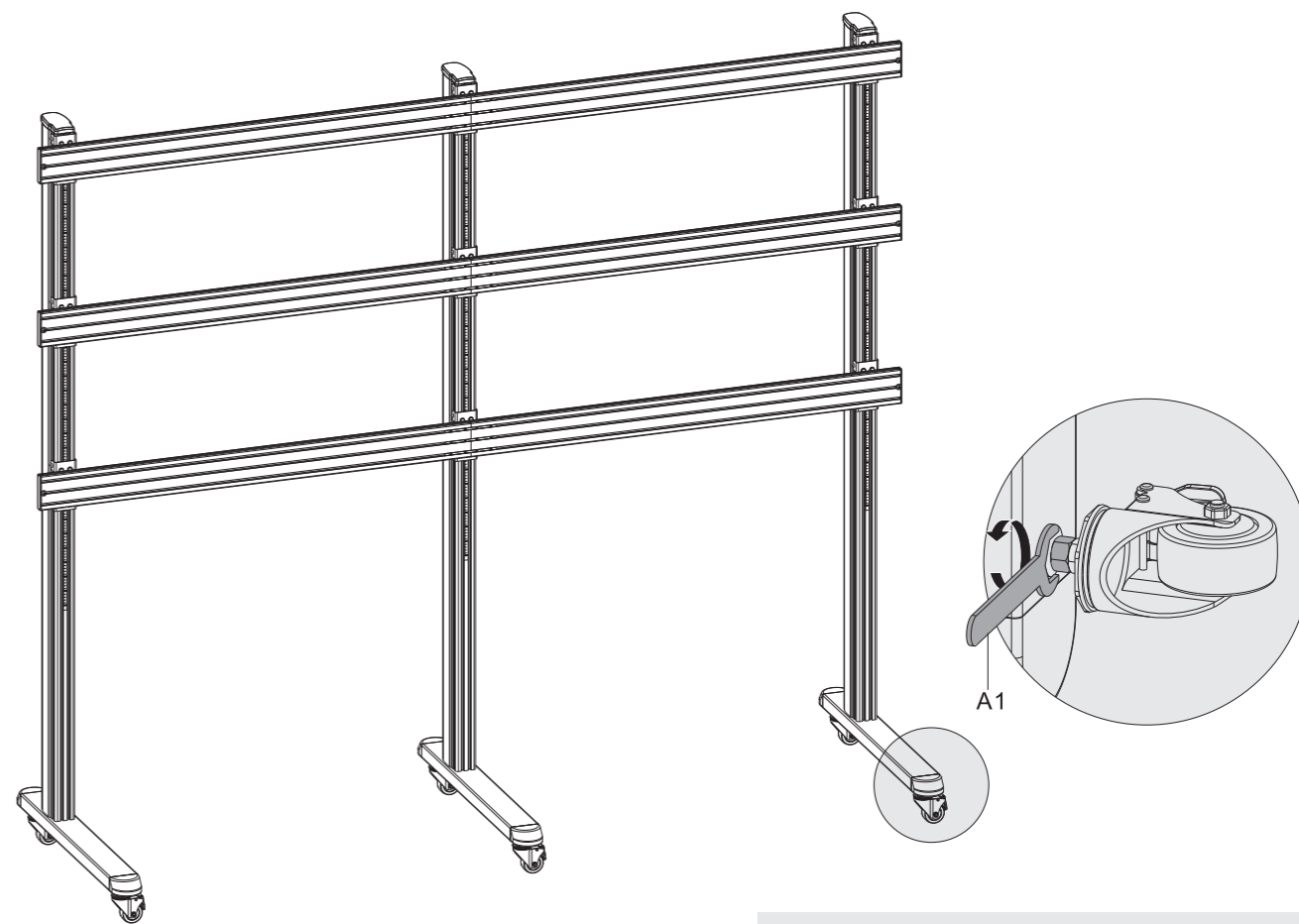
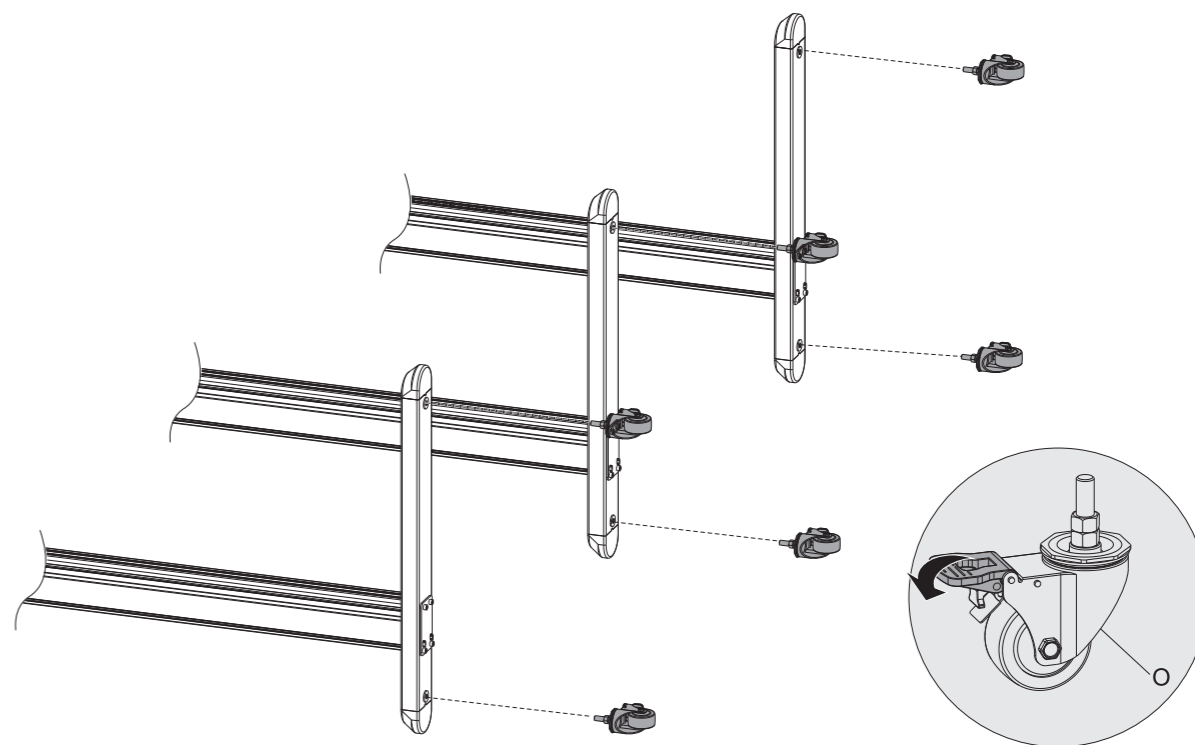

Note: Lock the brakes on the casters to avoid any sudden movements during installation.

5b-1. Assemble the Base

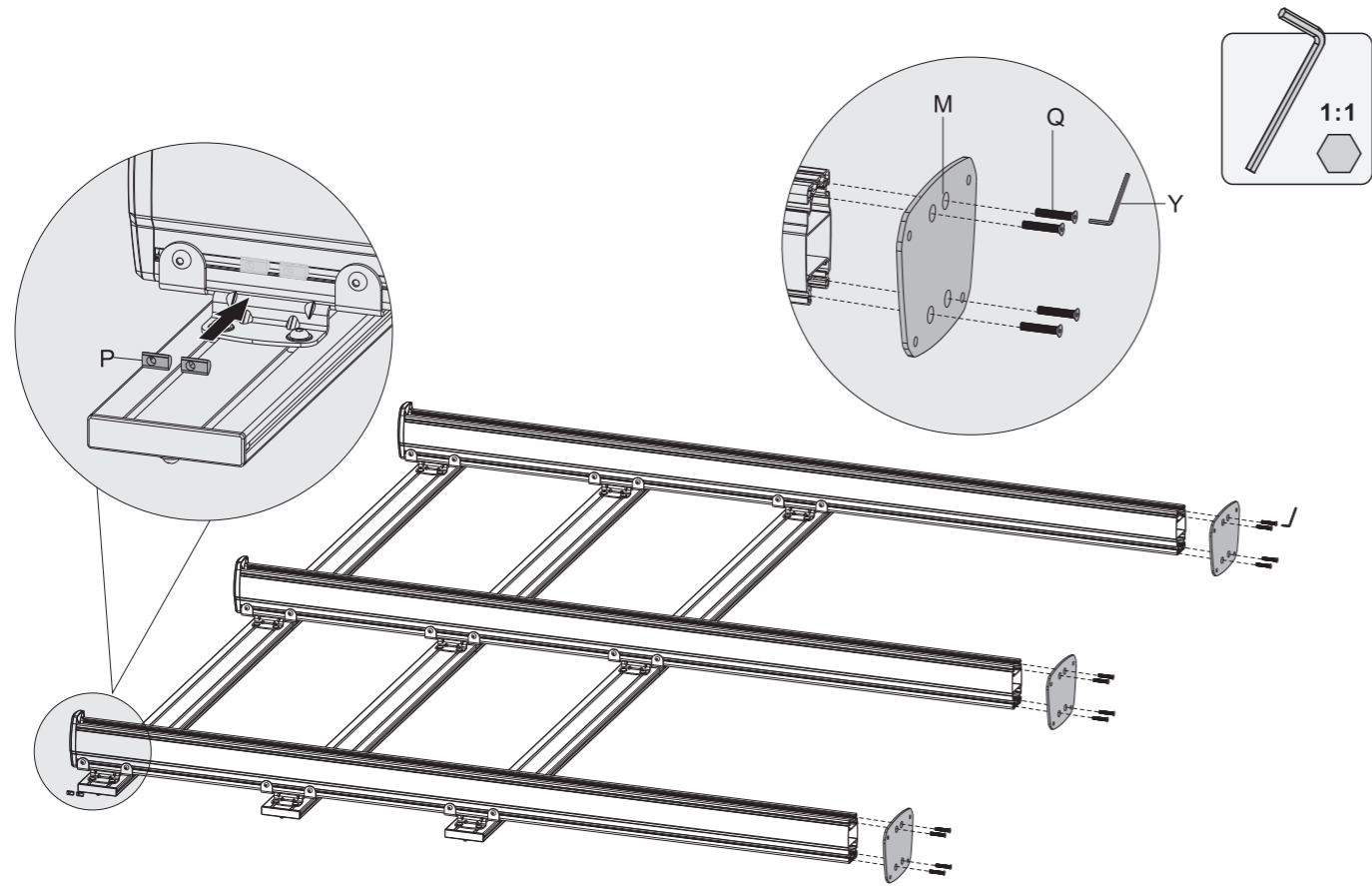

5b-2. Attach Stand to Solid Brick or Concrete

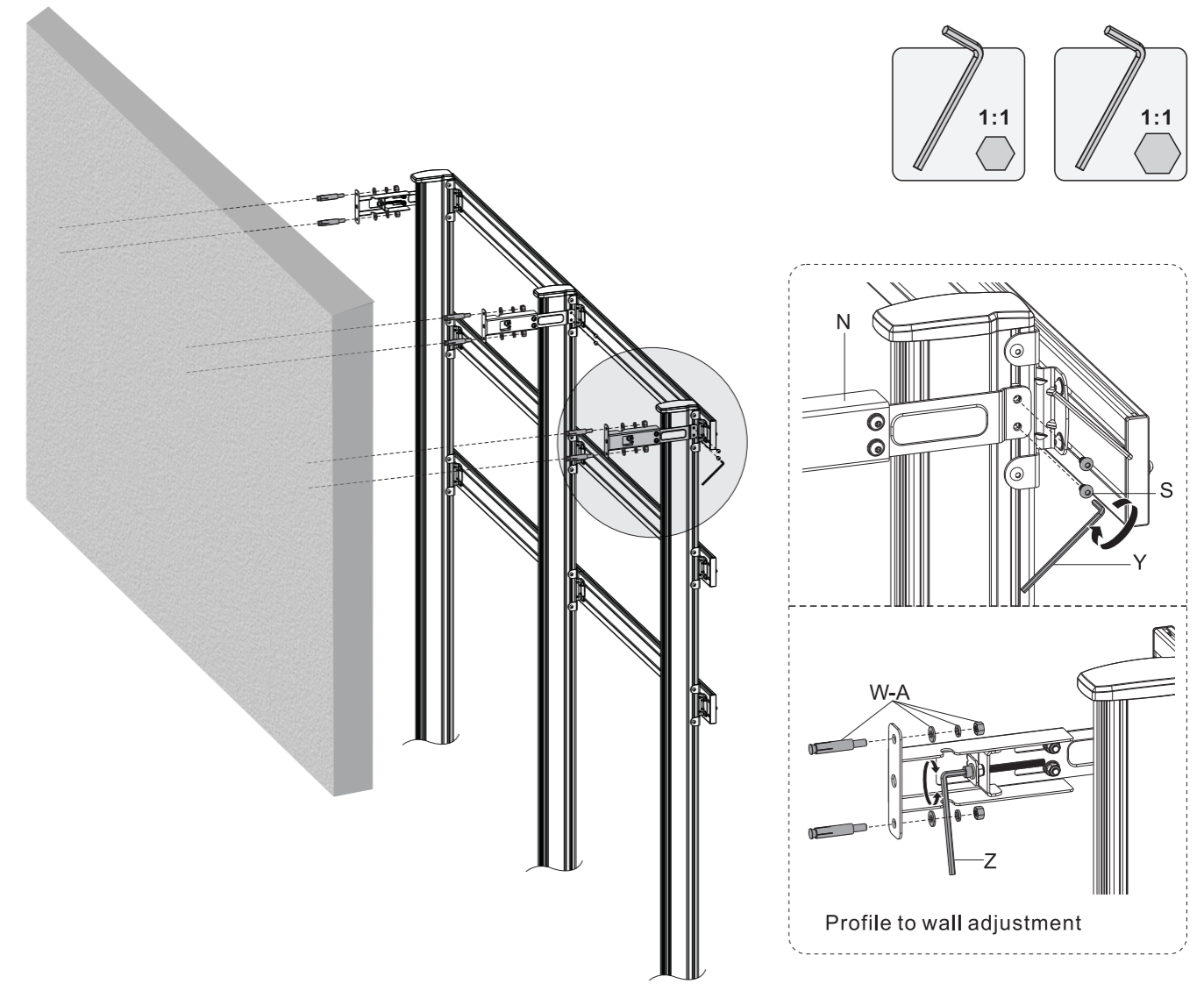
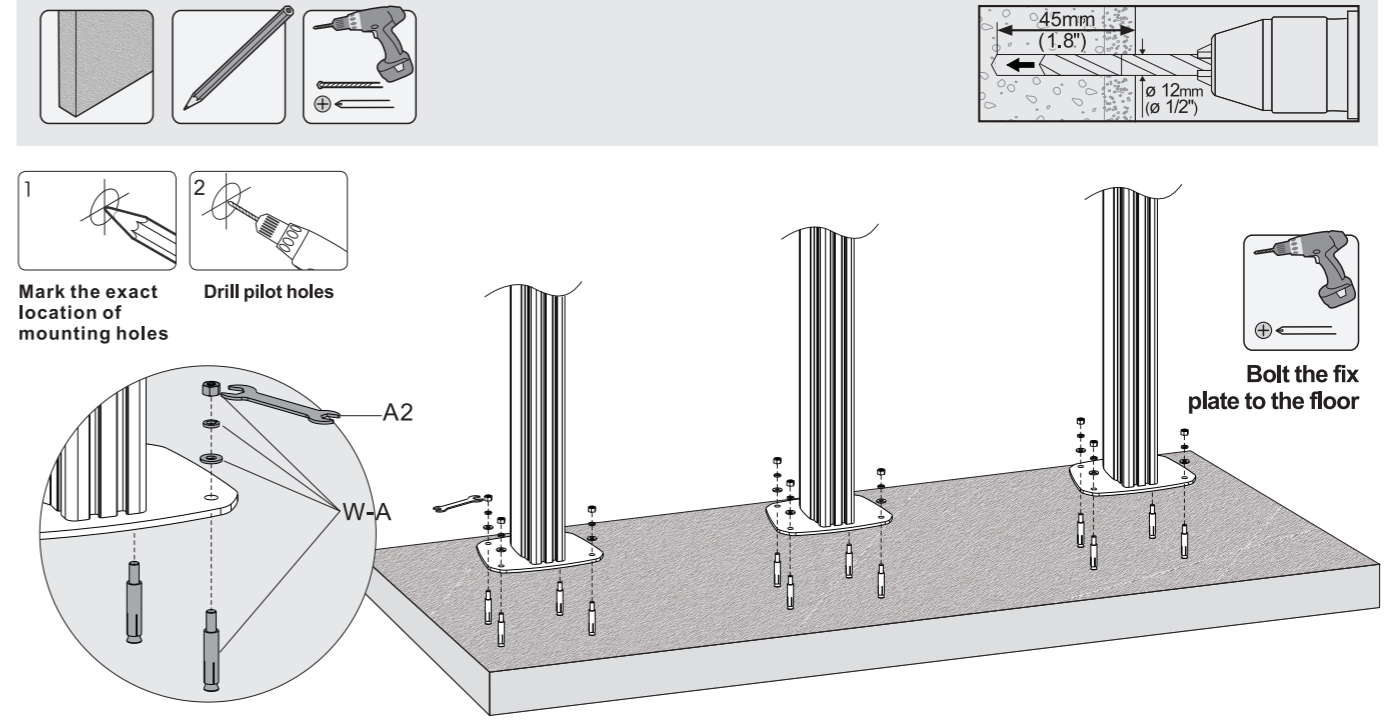
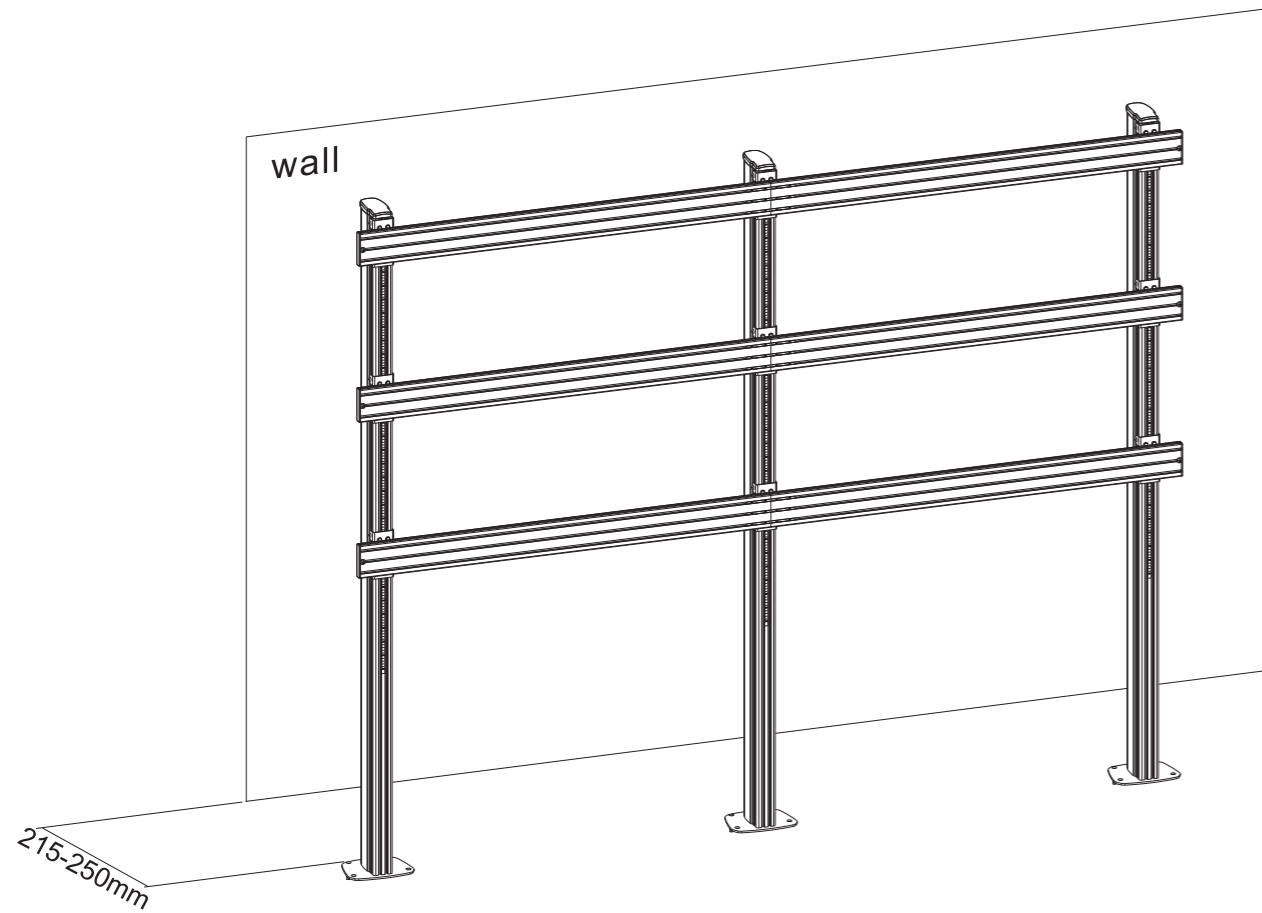

6. Attach TV Bracket

With the arrow pointing up.

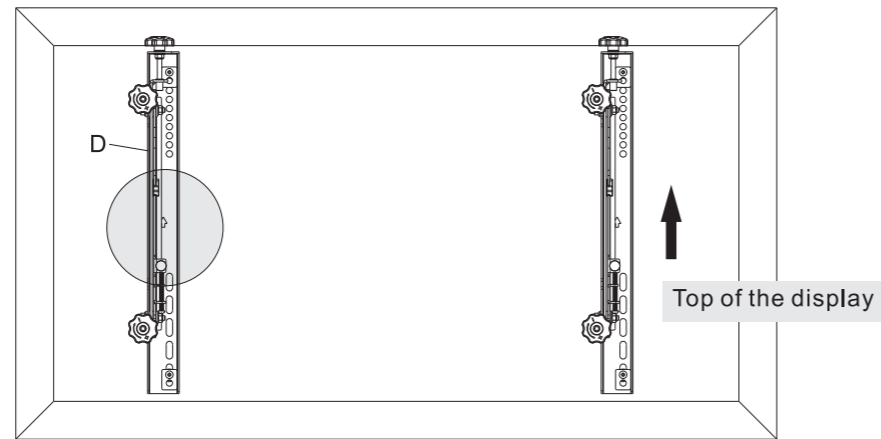
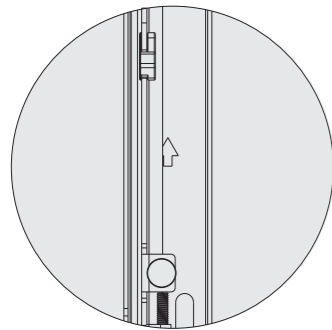

6a. Attach TV Bracket to Flat Back Screen

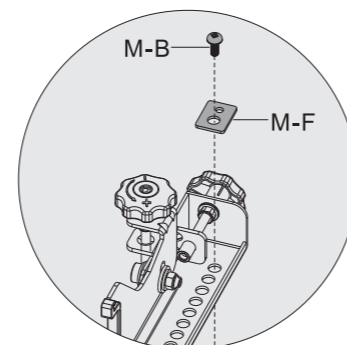
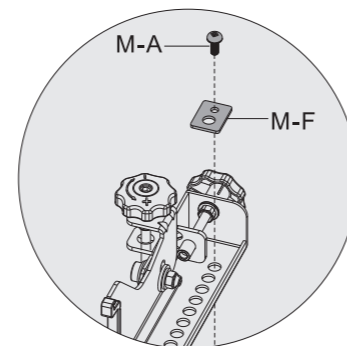
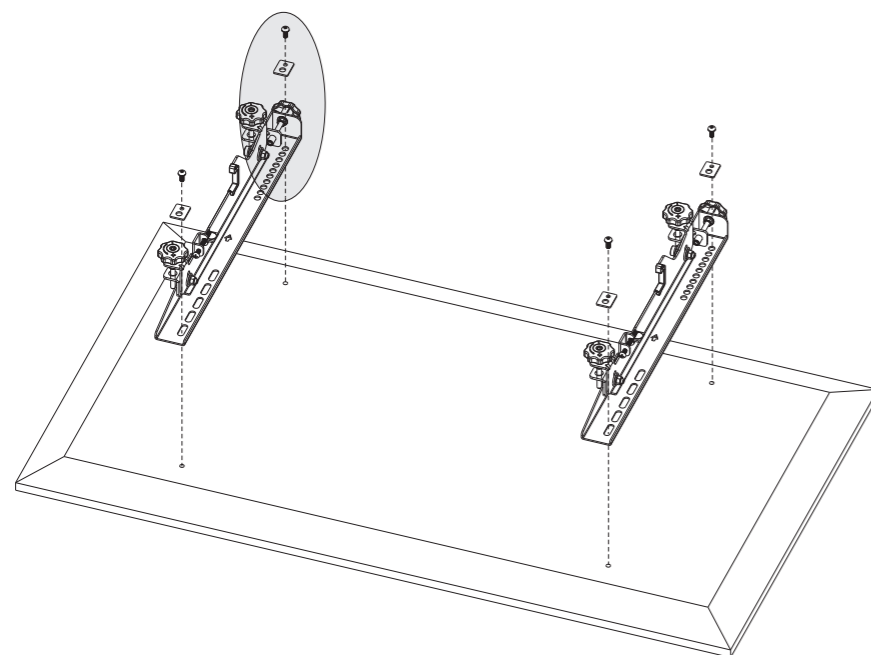
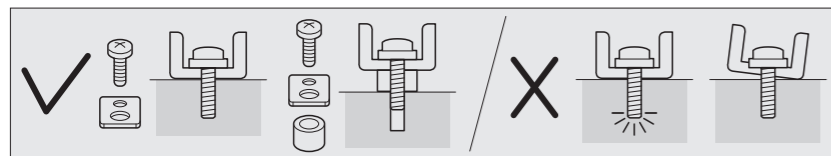

6b. Attach TV Bracket to Irregular Back Screen

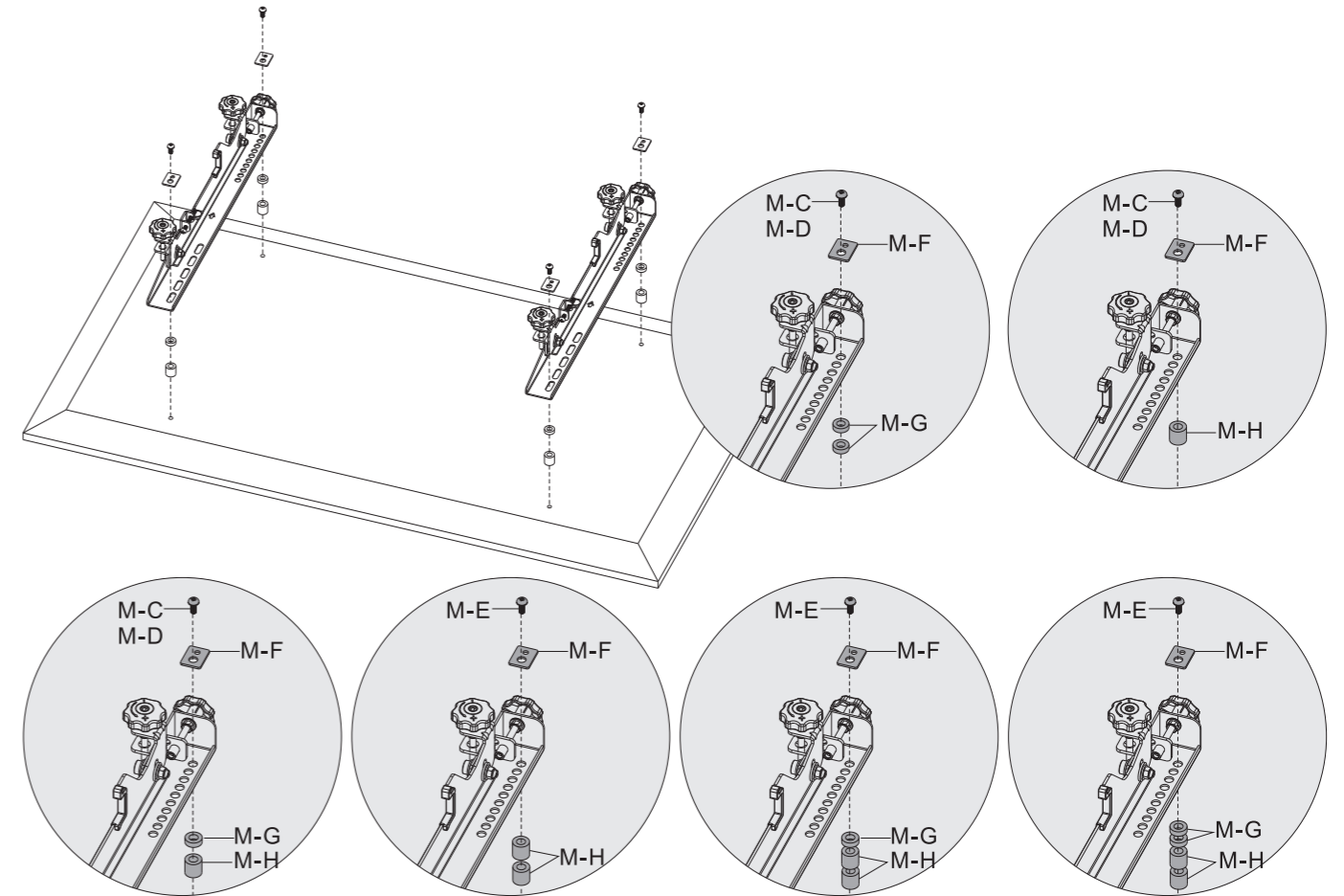

		1:1	
M-A			
M-B			
M-C			
M-D			
M-E			
M-F			
M-G			
M-H			

Note: Choose the appropriate screws, washers and spacers (if necessary) according to the type of screen.
 • Position the adapter brackets as close as possible to the center of the display.
 • Screw the adapter brackets onto the display.

Tighten all screws but do not over tighten.

7. Hang the Screen

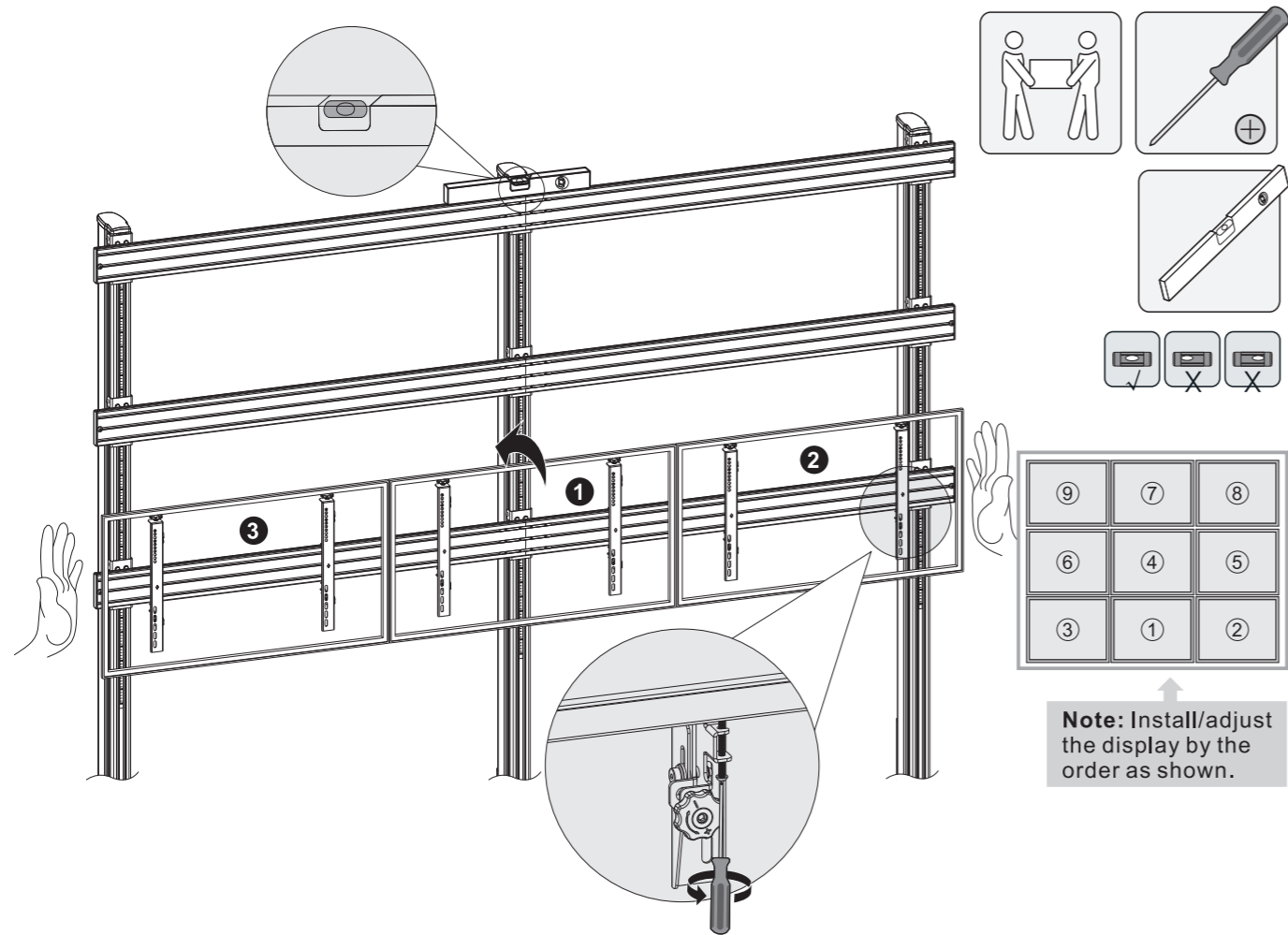

8. Precise Display Alignment

Z AXIS Adjustment Knob for Height Adjustment / Screen Leveling
Y AXIS Adjustment Knob for Depth Adjustment

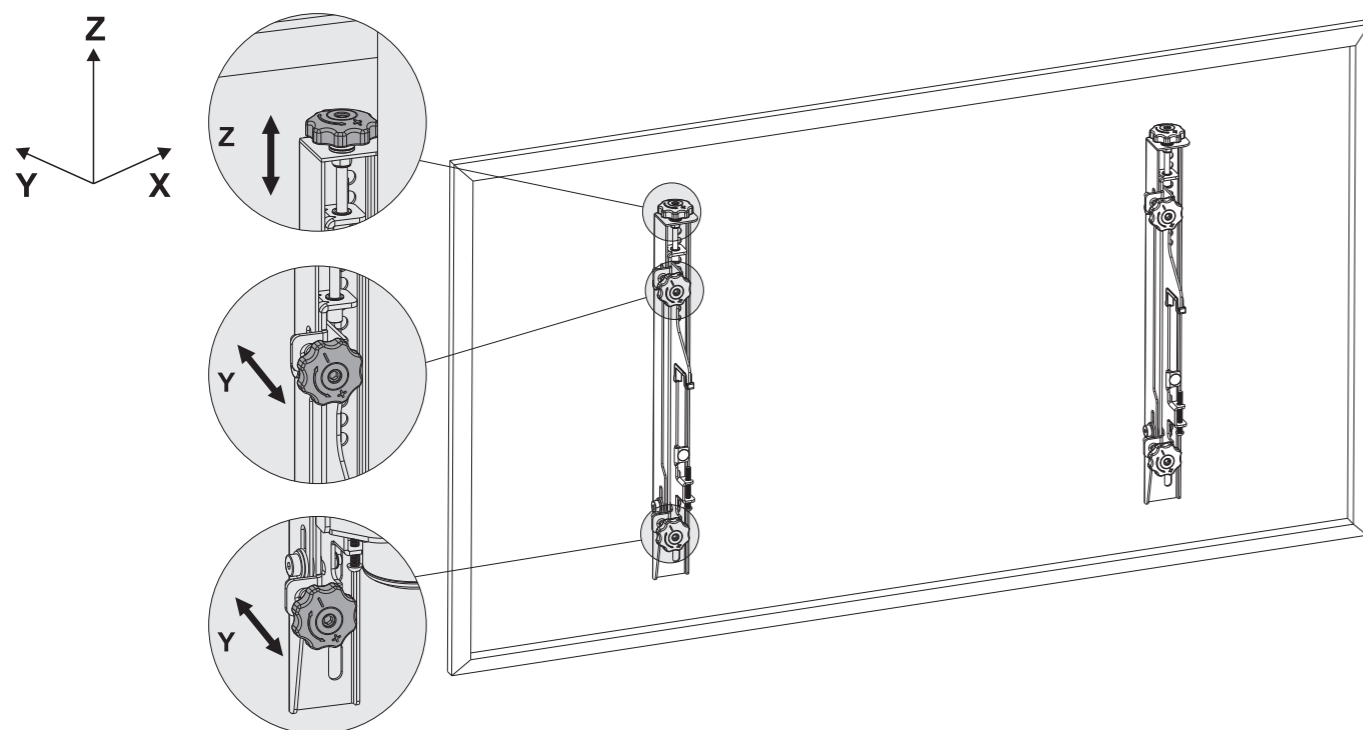

9. Cable Management

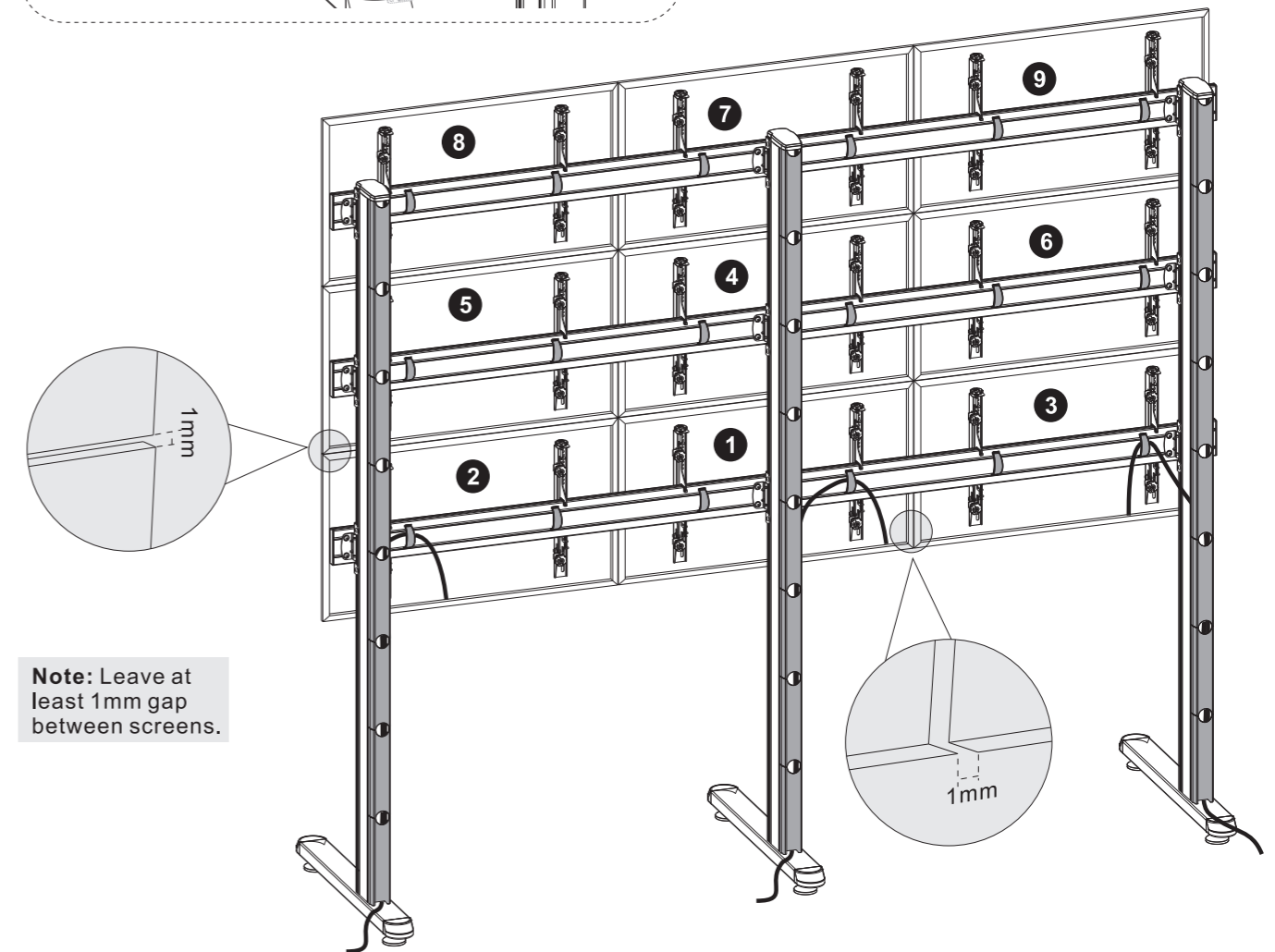
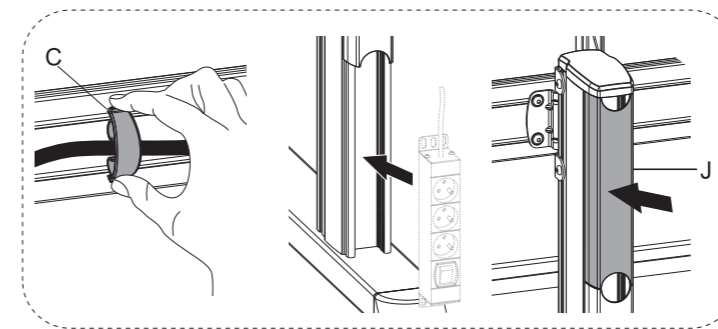

Maintenance

- Check that the bracket is secure and safe to use at regular intervals (at least every three months).
- Please contact your distributor if you have any questions.